

NOTICE: Please inspect the unit thoroughly before installation to make sure it has not been damaged during transportation.

If you have any questions please call LASCO Bathware's Technical Services Department at 800-877-2005.

IMPORTANT! Before installation begins:

- a. **READ ALL INSTALLATION INSTRUCTIONS COMPLETELY. IMPROPER INSTALLATION WILL VOID THE WARRANTY.**
- b. Make sure that walls and floors meet fire safety requirements of local building code and/or FHA/HUD Minimum Property Standards.
- c. Casting plaster/plaster of paris (foundation materials) or ledger strip support for Lascoat and acrylic shower pans is **MANDATORY**.
NOTE: Finished alcove must have interior dimensions shown in rough-in matrix to permit installation of unit. [See Page 2]

Pre Installation Requirements:

- a. In remodeling, if necessary, add studs at each end to provide a vertical nailing surface for the side nailing flanges of bath fixture product.
- b. To avoid obstruction during installation make sure that supply lines, spout pipe and valve plumbing do not project into alcove.
- c. Shower pans require a 6" (150mm) diameter floor opening for 2" (50mm) IPS drain fitting connection. [See Diagram 1]
NOTE: Be sure floor opening location matches left-hand or right-hand bath fixture drain location.
- d. Use of casting plaster/plaster of paris (foundation material) is recommended for all construction applications (i.e. hotels, motels, dormitories, health clubs, residential homes, apartments, etc.).

Installation

- Make sure framed-in alcove is of proper size per LASCO dimensions, square, and plumb; check floor for levelness.
- Place pan in alcove with the front skirt firmly on the floor. **The pan should be set level.** To check, use a 3' (915mm) long (minimum) level on top of the ledge on both ends of pan and on top of dam. [See Diagram 2]
- After leveling pan, mark each stud (or concrete or block wall) immediately above the back horizontal flange. Remove pan from alcove.
- Measure the distance between the top of the back horizontal flange and the bottom of the pan ledge (approximately. 1½" (40mm)). Carefully mark this dimension on the back studs (or wall), below the first mark.
- Ledger Strip (optional): Fasten a 1" x 3" (25mm x 75mm) ledger strip along rear of alcove and along both sides in corner installations (immediately below the lower marks made on framing).
NOTE: Fasteners to wood framing - 1" (25mm) galvanized roofing nails or 1" (25mm) pan head screws; to steel studs - drill flanges and studs with ⅜" (5mm) carbide bit and fasten with #10 x 1" (25mm) sheet metal screws with washers; to concrete/block walls use 1" (25mm) concrete nails with nailing tool or impactor. **NOTE:** Pre drilling acrylic flanges is required. Pre-drilling gelcoat nailing flanges is recommended to prevent cracking the unit.
- Bottom support: Casting plaster/plaster of paris (herein referred as foundation materials), is highly recommended for Lascoat and acrylic shower pans. The following applies for foundation materials:
In a bucket, mix foundation material. Place three or four mounds of plaster on the subfloor around but away from drain hole. The mounds should be placed high enough so that when the pan is set, it will cause the plaster to displace and spread. [See Diagram 2]
- Place pan into alcove with front skirt firmly on floor and depress plaster mounds. Make certain that unit is level [See Diagram 2].
The pan should be set level.
 - a. Spot-fasten the four corners of the nailing flanges.
 - b. Nail fasten at each stud through the topside flanges; through back flange, at each stud (concrete; 16" (405mm) on center), working from both ends toward back center. [See Diagram 2]
- When other than cementitious backer board plaster is to be used, furring strips as thick as nailing flanges are recommended for installation on studs above the installed LASCO unit to assure walls will be flush. 100% silicone sealant with mildew resistant properties should be applied between the backer board and horizontal surface of unit. Then finished wall materials can be applied. [See Diagram 3]
- If ceramic tile is used as a wall covering, the intersection of materials (tile to pan) should be porous to allow water to escape. Leaving the valley detail on the pan clear of all materials will allow water to escape in pan draining area. [See Diagram 3: Detail A and B] Refer to applicable building codes for proper finishing of other trades.
- Door Enclosures: Use LASCO shower door model for an engineered fit. Reference the Complete Works Catalog or the LASCO Bathware website for the shower door installation guide.
NOTE: Where local codes specify minimum door openings, shower stalls may require swing (not sliding) doors.
- 3232-PAN or 3232-APAN do not carry the UPC seal and are not approved by some municipal plumbing codes due to inside dimensions. Check local building codes.

Clean-up

CAUTION: DO NOT USE heat, or solvent based cleaning fluids

NOTE: Do not remove adhered label. Warranty/User Maintenance Label must be left for occupant. (Required by ANSI Z124)

1. To prevent staining and/or blistering: Remove all construction debris before filling product for plumbing inspection. Drain and wipe clean immediately after the inspection process. Use sponge with warm water and liquid detergent. Do not use abrasive cleaners, such as scouring powders or pads, steel wool, scrapers, sandpapers or anything else that may scratch, mar or dull the finish. Roofing tar or paints may be removed with turpentine, rubbing alcohol or paint thinner (not lacquer thinner).
2. Plaster may be removed by scraping with the edge of a piece of wood or rigid plastic. Do not use a metal scraper or utensil to remove plaster or paint from finish.
3. Dulled areas can be restored to a high gloss with white or cream-colored automotive rubbing compound, followed by application of a coat of good quality white automotive polish (or similar) and buff with a soft cloth.
4. Remove minor scratches with 600 grit wet/dry sandpaper, followed by Step #3 (above).
5. Major gouges require professional repair.

User Maintenance Instructions

IMPORTANT! Use only recommended cleaners and procedures described herein. Use of other materials and methods may damage your bath fixture and void the warranty.

- For normal cleaning: Never use abrasive cleaners such as scouring powders or pads, steel wool, scrapers, sandpaper or anything else that could scratch or dull the surface of your LASCO unit. Instead, use warm water and liquid detergents or non-abrasive cleansers, especially those bathroom cleaners recommended for cleaning fiberglass.
- To keep your LASCO bath fixture sparkling clean: Apply a coat of good quality automotive paste wax or polish and buff to a high shine with a soft cloth or towel. Repeat every six months for easier cleaning and long lasting protection.
NOTE: DO NOT WAX standing surfaces of the unit bottom (this includes textured, slip resistant standing surfaces), which could result in greater risk of slipping and personal injury.
- To restore a scratched or dull unit: Use an automotive polishing compound applied with a clean cotton rag. Rub scratches and dull areas vigorously. Wipe off residues. Follow with automotive wax treatment described above.
- To remove adhesive: Try 3-M Natural Cleaner, De-Solv-It or similar materials. If residues remain, saturate a small, white, cotton rag with nail polish remover (naphtha or acetone) and rub vigorously until the adhesive dissolves and disappears. These solvents are highly flammable and must be used sparingly and with caution. Do not smoke or permit others to do so. Make sure all nearby heating devices (including pilot lights) are extinguished. Do not allow solvent to go down the drain. Make sure not to contact plastic drain grates or other synthetic materials.
- Rubber Mats: If you use a rubber "anti-skid" mat, make sure to remove it from the unit after each use to avoid harm to the surface finish.
- Hard Water: Water in certain regions, if not wiped up after bathing/showering, may cause fading of some bath fixture colors. This is a natural occurrence beyond LASCO's control. (See Warranty)

CAUTION: When using any cleaning or polishing materials, make sure to read and follow all package instructions carefully. Wear rubber gloves at all times and avoid contact with eyes, skin, clothing, rugs and furnishings. Make sure all residues are rinsed off thoroughly.

Rough-In Dimensions

MODEL	OW Overall Width	OD Overall Depth	OH Overall Height	DH Dam Height	RI Rough-In	RC Rough- Center	DR/DC Drain Diameter Drain Clearance	Fax-On- Demand Doc. #	Approx. Wt. lbs. (kg) Net/Pkgd.
3232-PAN	32" (815)	32" (815)	7¼" (185)	6" (150)	16" (405)	16" (405)	¾" (80) / ¼" (30)	2001	33 (14) / 38 (17)
3636-PAN	36" (915)	36" (915)	7¼" (185)	6" (150)	17½" (445)	18" (460)	¾" (80) / ¼" (30)	2002	36 (16) / 41 (19)
3642-PAN	36" (915)	42" (1065)	7¼" (185)	6" (150)	20½" (520)	18" (460)	¾" (80) / ¼" (30)	2003	41 (19) / 46 (21)
3642-2T	36" (915)	42" (1065)	7¼" (185)	6" (150)	20½" (520)	18" (460)	¾" (80) / ¼" (30)	2004	41 (19) / 46 (21)
4234-PAN	42" (1065)	34" (865)	7¼" (185)	6" (150)	16½" (420)	21" (535)	¾" (80) / ¼" (30)	2006	34 (16) / 39 (18)
4242-PAN	42" (1065)	42" (1065)	7¼" (185)	6" (150)	20½" (520)	21" (535)	¾" (80) / ¼" (30)	2007	47 (21) / 52 (24)
4834-PAN	48" (1220)	34" (865)	7¼" (185)	6" (150)	16½" (420)	24" (610)	¾" (80) / ¼" (30)	2008	38 (17) / 53 (24)
6034-PAN	60" (1525)	34" (865)	7¼" (185)	6" (150)	16½" (420)	30" (760)	¾" (80) / ¼" (30)	2009	58 (26) / 63 (29)
6034-PAN L/R	60" (1525)	34" (865)	7¼" (185)	6" (150)	6" (150)	15½" (395)	¾" (80) / ¼" (30)	2037	58 (26) / 63 (29)
6042-PAN	60" (1525)	42" (1065)	7¼" (185)	6" (150)	20½" (520)	30" (760)	¾" (80) / ¼" (30)	2010	59 (27) / 64 (29)

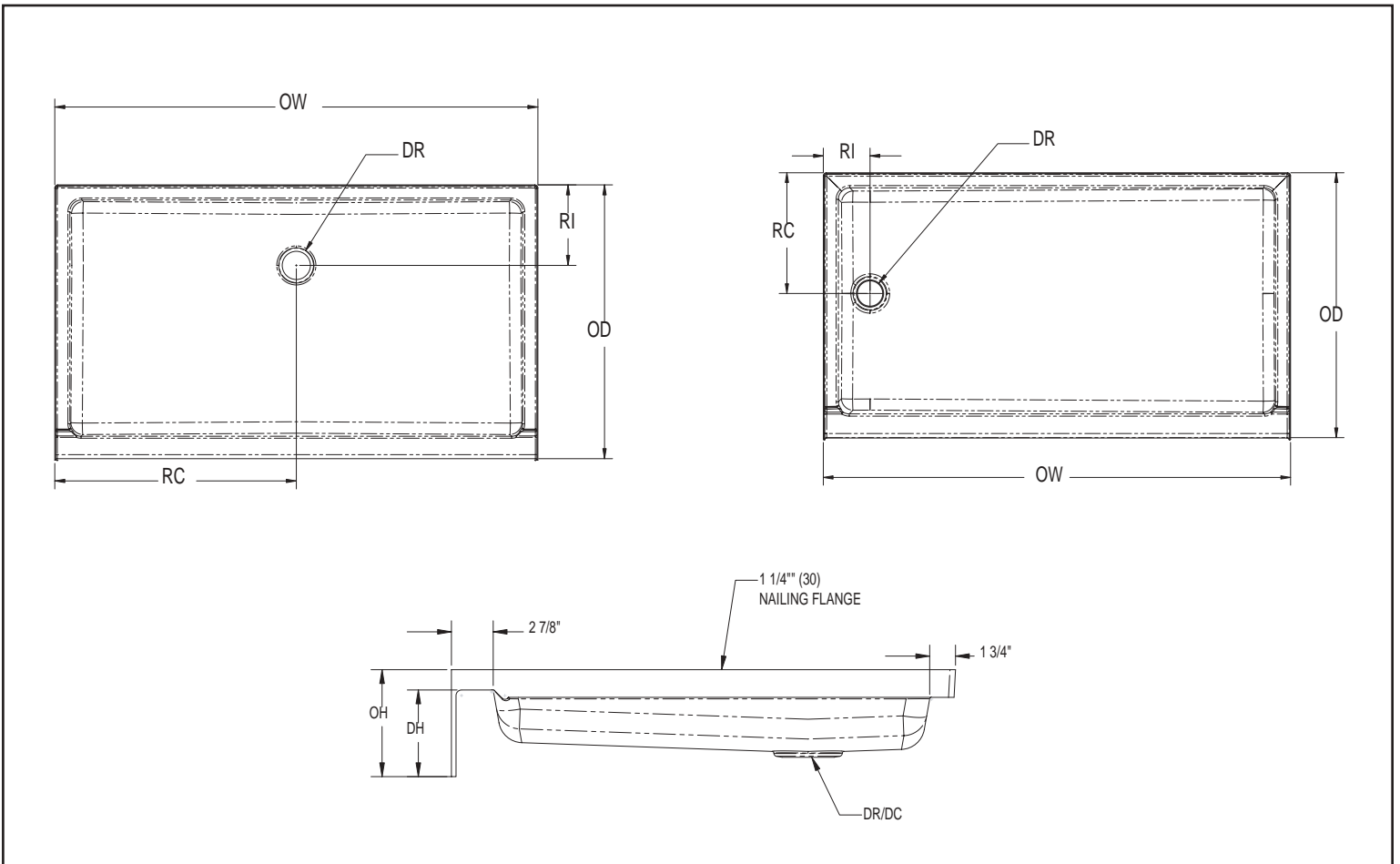

Diagrams

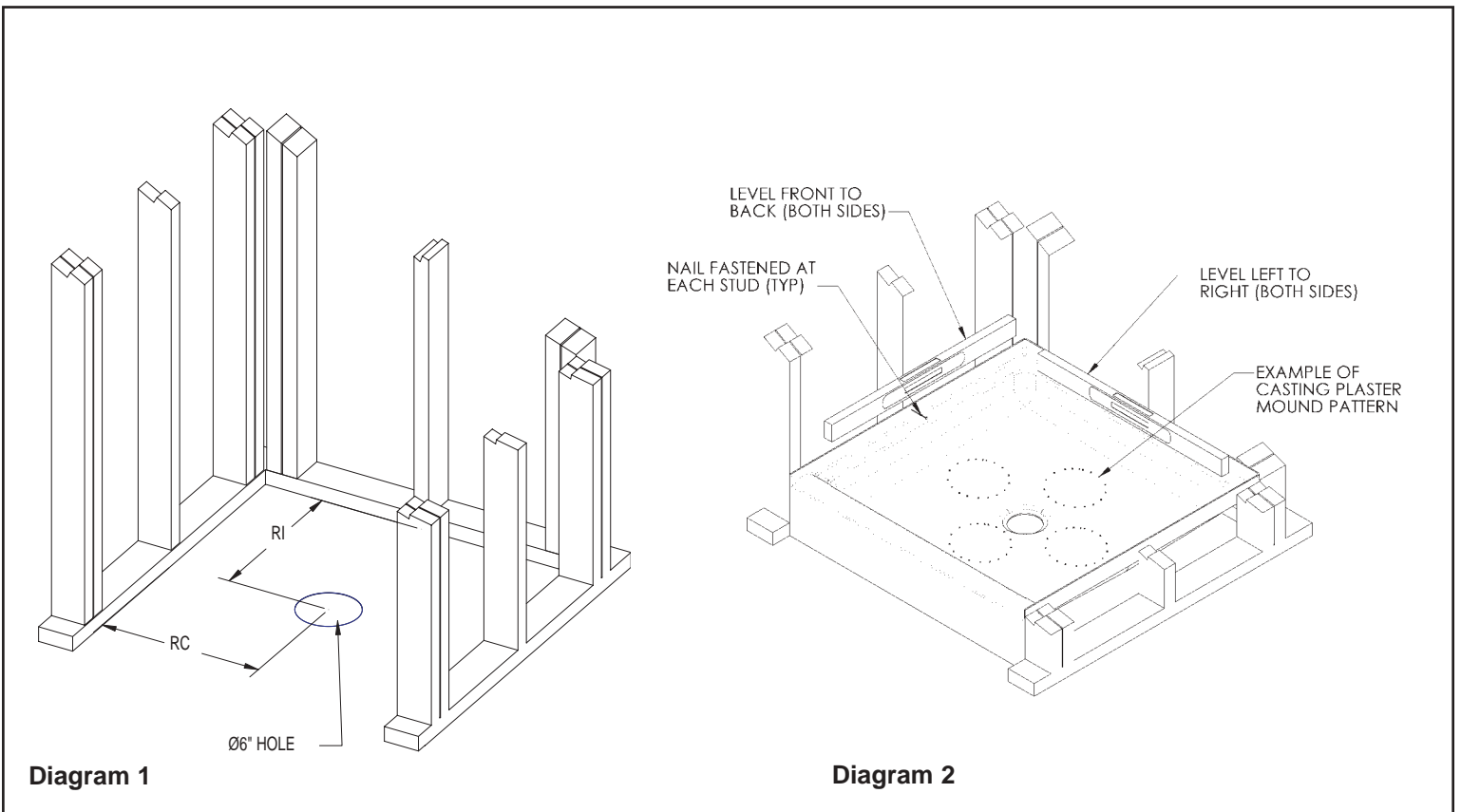

Diagram 1

Diagram 2

Section Detail A

Section Detail B

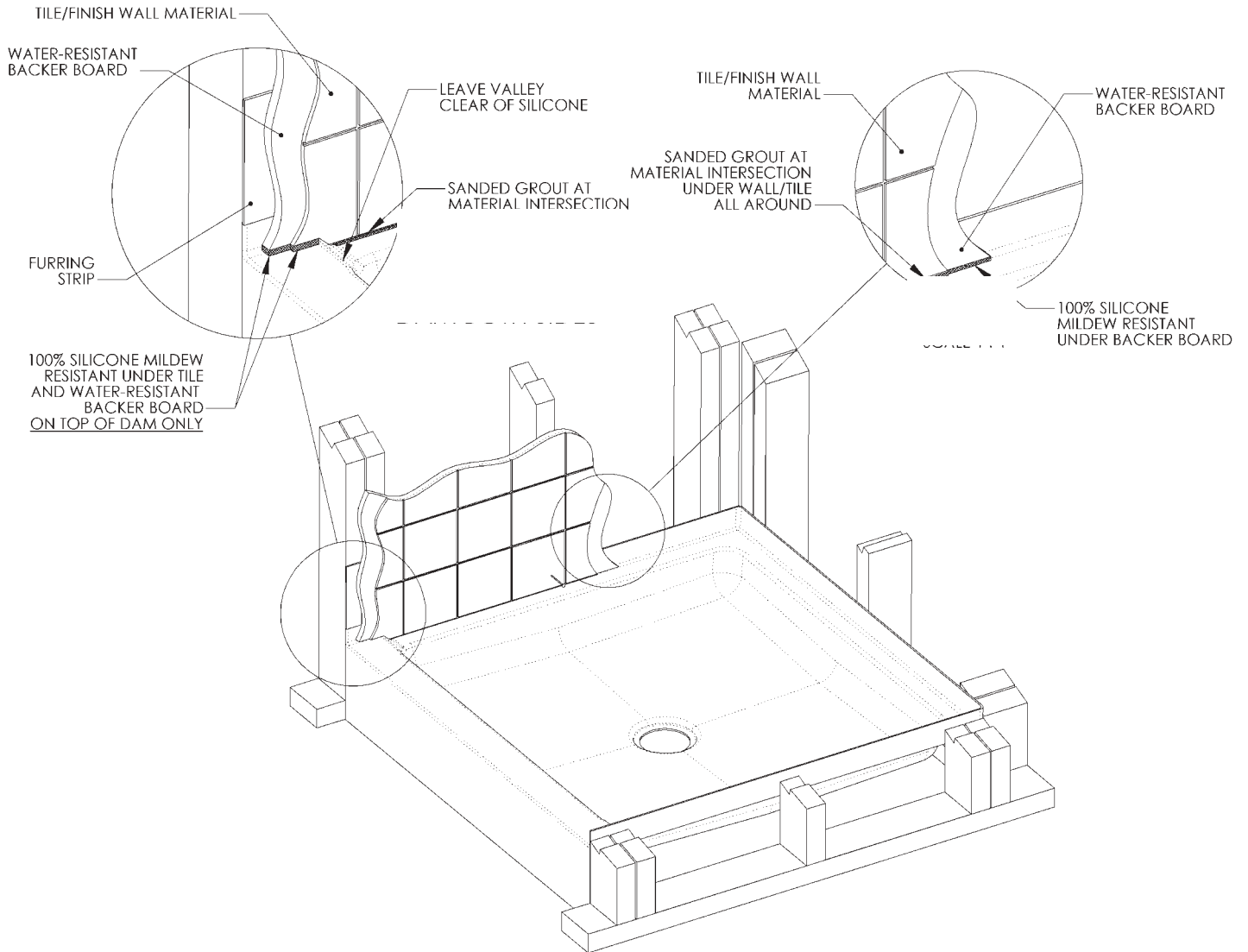

Diagram 3

Field Service/Repairs

West Central
 P.O. Box 310
 Moapa, NV 89025
 PH: 800-335-5151, 702-864-2100
 FAX: 800-799-2158

North Central
 888 W. Broadway
 Three Rivers, MI 49093
 PH: 800-444-1426
 FAX: 269-273-3053

North East
 40 Industrial Road
 Conewago Industrial Park
 Elizabethtown, PA 17022
 PH: 800-444-0781
 FAX: 717-367-4722

South West/South Central
 151 Industrial St.
 Lancaster, TX 75134
 PH: 800-876-3044
 FAX: 972-227-0769

Mid-Atlantic
 P.O. Box 1177
 Halifax County Ind'l Pk.
 So. Boston, VA 24592
 PH: 800-444-0832
 FAX: 434-572-1794

West
 3261 E. Miraloma Ave.
 Anaheim, CA 92806
 PH: 800-877-0464, 714-961-9735
 FAX: 800-328-6465

South East
 210 S. Harris St.
 Cordele, GA 31015
 PH: 800-444-0926
 FAX: 229-273-6838

Rocky Mtn./North West
 801 Northern Pacific
 Yelm, WA 98597
 PH: 800-444-5126
 FAX: 360-458-3024

Customer Service/ Sales Order

Customer Service/Sales Order
 C/O Skymark Tower
 1521 No. Cooper, Ste. 500
 Arlington, TX 76011
 PH: 800-945-2726, 817-801-8300
 FAX: 866-544-5353

Technical Services Department
 8101 E. Kaiser Blvd.
 Anaheim, CA 92808
 PH: 800-877-2005, 714-993-1220